

# YASKAWA

# MOTOMAN HC10, HC10DT

**Human-Collaborative Robot**  
**6 integrated Torque Sensors**



HC10

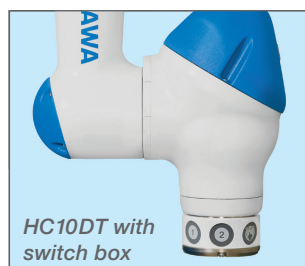

HC10DT with  
switch box

MOTOMAN HC10 is a 6 axes human-collaborative robot with a payload of up to 10 kg. Operator's safety is assured by a Power and Force Limit technology that stops the robot in case of contact with an operator.

The robot arm can be hand guided by an operator and robot positions and gripper operation can be registered via so called "Easy Teaching Switch Box". These features offer time saving during the robot programming. The robots arm geometry was designed to avoid pinch points (finger).

The MOTOMAN HC10 robot can operate without additional protective measures like a safety fence, depending on the risk assessment. This saves space and costs. Its installation area is very flexible and therefore able to operate at different workplaces.

## KEY BENEFITS

### Controller

- Fully industrial robot controller
  - YRC1000 for HC10 and HC10DT
  - YRC1000micro for HC10DT

### High safety

- Contact force between operator and robot is limited to a safe level
- Arm geometry designed to avoid pinch points (finger protection)
- Safety standards – applications for Industrial robots: ISO 10218-1 (5.10.5 Power and Force limiting)
- Complies to ISO TS 15066
- Safety functions industrial robot controller: ISO 13849-1, PLd, Cat. 3
- Functional Safety Unit included

### Easy teaching

- Move the robot arm directly via hand guiding function: easy teaching mode with a switch box

### No safety fence

- Depending on the application, the HC10 can be used without a safety fence

Controlled by  
**YRC1000**

Controlled by  
**YRC1000  
micro**

[www.yaskawa.eu.com](http://www.yaskawa.eu.com)

# MOTOMAN HC10

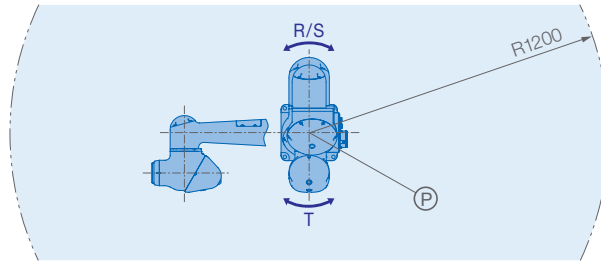
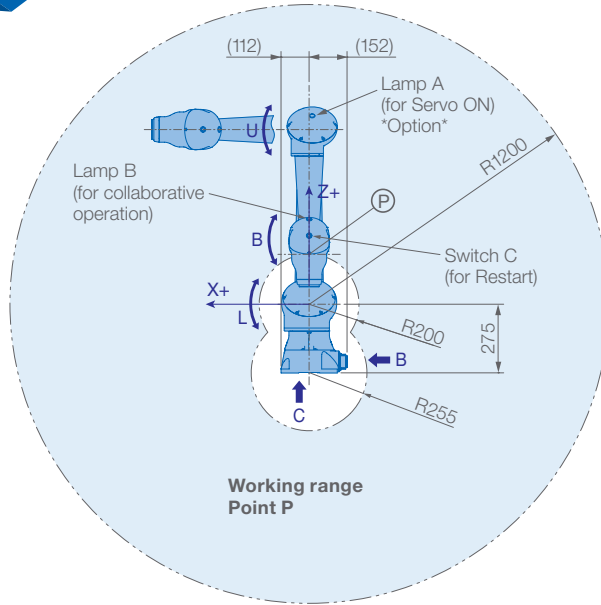
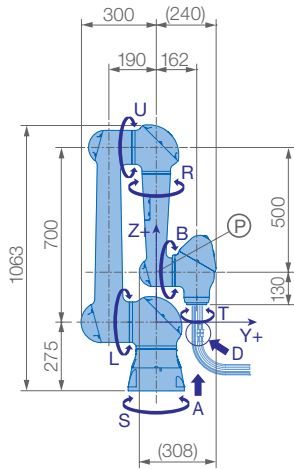

## Allowable wrist load

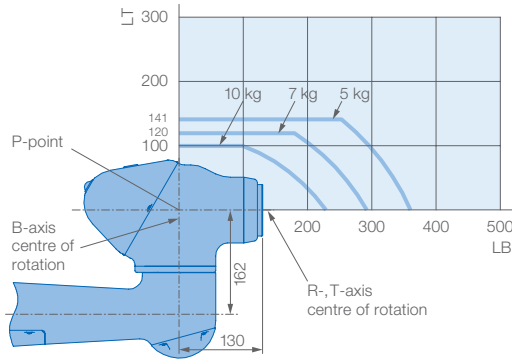

## View A

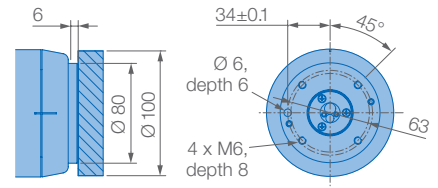

## View B

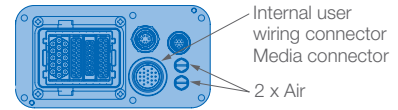

## View C

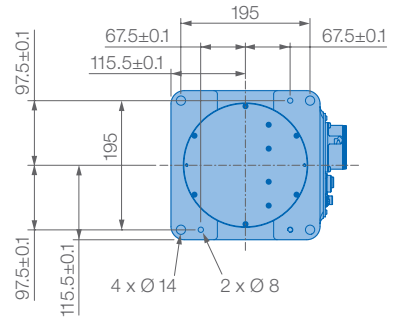

Mounting options: Floor, ceiling, wall, tilt\*

\* tilt with condition of angle – see table below

Robot installation angle $\theta$ [deg.]	S-axis operating range [deg.]
$0 < \theta \leq 60$	no limit
$60 < \theta$	within $\pm 60$

## View D

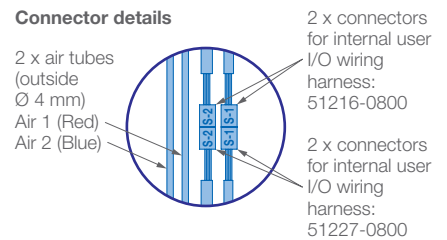

Specifications HC10					
Axes	Maximum motion range [°]	Maximum speed [°/sec.]	Allowable moment [Nm]	Allowable moment of inertia [kg · m <sup>2</sup> ]	Controlled axes
S	±180	130	–	–	6
L	±180	130	–	–	Max. payload [kg]
U	+355/-5	180	–	–	Repeatability [mm]
R	±180	180	27.4	0.78	Max. working range R [mm]
B	±180	250	27.4	0.78	Temperature [°C]
T	±180	250	9.8	0.1	Humidity [%]
					Weight [kg]
					Power supply, average [KVA]

\* during operation \*\* when the soft cover (optional) is attached

# MOTOMAN HC10DT

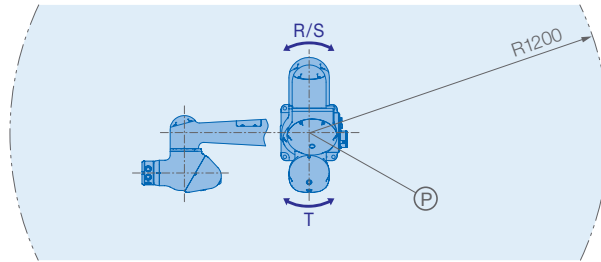
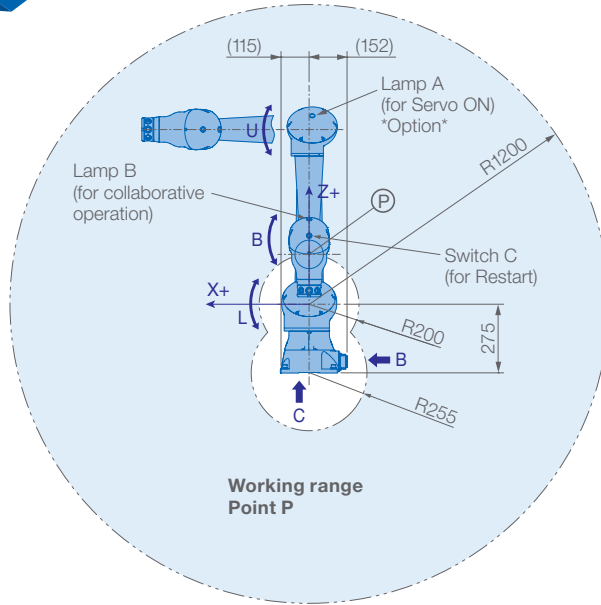
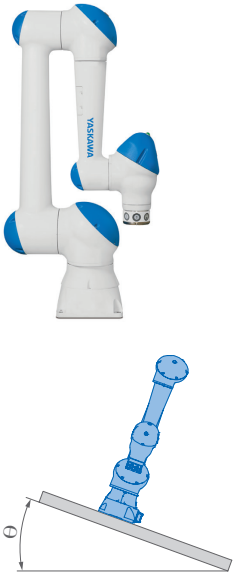
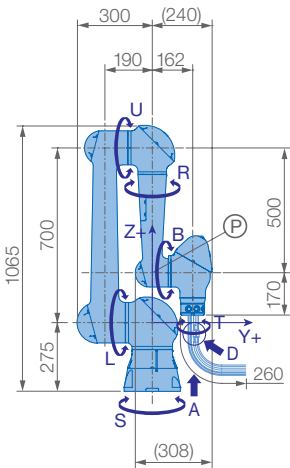

## Allowable wrist load

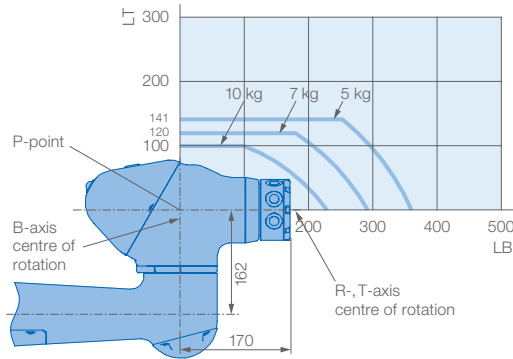

## View A

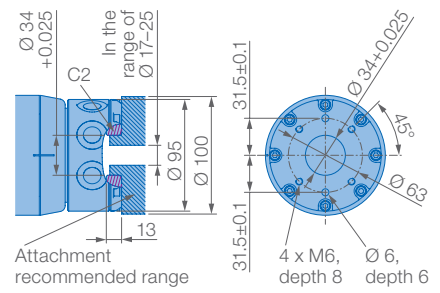

## View B

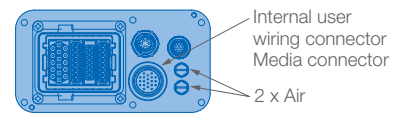

## View C

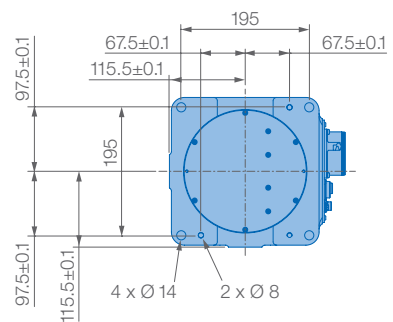

Mounting options: Floor, ceiling, wall, tilt\*

\* tilt with condition of angle – see table below

Robot installation angle $\theta$ [deg.]	S-axis operating range [deg.]
$0 < \theta \leq 60$	no limit
$60 < \theta$	within $\pm 60$

## View D

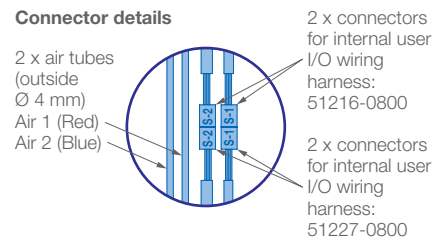

## Specifications HC10DT

Axes	Maximum motion range [°]	Maximum speed [°/sec.]	Allowable moment [Nm]	Allowable moment of inertia [kg · m <sup>2</sup> ]	Controlled axes	6
S	±180	130	–	–	Max. payload [kg]	10
L	±180	130	–	–	Repeatability [mm]	±0.1
U	+355/–5	180	–	–	Max. working range R [mm]	1200
R	±180	180	25.3	0.73	Temperature [°C]	0 to +40
B	±180	250	25.3	0.73	Humidity [%]	20 – 80
T	±180	250	9.8	0.1	Weight [kg]	48
					Power supply, average [KVA]	1

## YASKAWA GROUP

AT	YASKAWA Austria Schwechat/Wien +43(0)1-707-9324-15
CZ	YASKAWA Czech s.r.o. Rudná u Prahy +420-257-941-718
ES	YASKAWA Ibérica, S.L. Gavà/Barcelona +34-93-6303478
FR	YASKAWA France SARL Le Bignon +33-2-40131919
FI	YASKAWA Finland Oy Turku +358-(0)-403000600
GB	YASKAWA UK Ltd. Banbury +44-1295-272755
IT	YASKAWA Italia s.r.l. Torino +39-011-9005833
IL	YASKAWA Europe Technology Ltd. Rosh Ha'ayin +972-3-9004114
NL	YASKAWA Benelux B.V. Eindhoven +31-40-2895500
PL	YASKAWA Polska Sp. z o.o. Wrocław +48-71-7928670
RU	YASKAWA Nordic AB Moskva +46-480-417-800
SE	YASKAWA Nordic AB Torsås +46-480-417-800
SI	YASKAWA Slovenia Ribnica +386-1-8372-410
TR	YASKAWA Turkey Elektrik Ticaret Ltd. Sti. İstanbul +90-216-5273450
ZA	YASKAWA Southern Africa (PTY) Ltd Johannesburg +27-11-6083182

## DISTRIBUTORS

BG	ARAMET ROBOTICS Ltd. Yambol +359-885 317 294  Kammarton Bulgaria Ltd. Sofia +359-02-926-6060
DK	Robotcenter Danmark Løsning +45 7022 2477
EE	RKR Seadmed OÜ Tallinn/Estonia +372-68-35-235
GR	Gizelis Robotics Schimatari Viotias +30-2262057199
HU	Flexman Robotics Kft Budapest +36 1 259 0981
LT	Profibus UAB Panevezys +370-45-518575
NO	Skala Robotech AS Lierstranda +47-32240600
PT	ROBOPLAN Lda Aveiro +351-234 943 900
RO	Sam Robotics srl Timisoara +40-720-279-866  MPL Automation S.R.L. Satu Mare +40 (0) 261 750 741



## YASKAWA Headquarters

YASKAWA Europe GmbH  
Robotics Division  
Yaskawastraße 1  
85391 Allershausen, Germany  
Tel. +49 (0) 8166/90-0  
Fax +49 (0) 8166/90-103

robotics@yaskawa.eu.com  
www.yaskawa.eu.com

## YASKAWA ACADEMY and sales office Frankfurt

YASKAWA Europe GmbH  
Robotics Division  
Hauptstraße 185  
65760 Eschborn, Germany  
Tel. +49 (0) 6196/77725-0  
Fax +49 (0) 6196/77725-39

All drawing dimensions in mm.  
Technical data may be subject to change without previous notice.  
Please request detailed drawings at [robotics@yaskawa.eu.com](mailto:robotics@yaskawa.eu.com).

YR-1-06VXHC10-A00, YR-1-06VXHC10-A10  
A-07-2019, A-No. 180780

# YASKAWA